

SALES DRAWING SALES DRAWING SALES DRAWING SALES DRAWING SALES DRAWING

SALES DRAWING SALES DRAWING SALES DRAWING SALES DRAWING SALES DRAWING

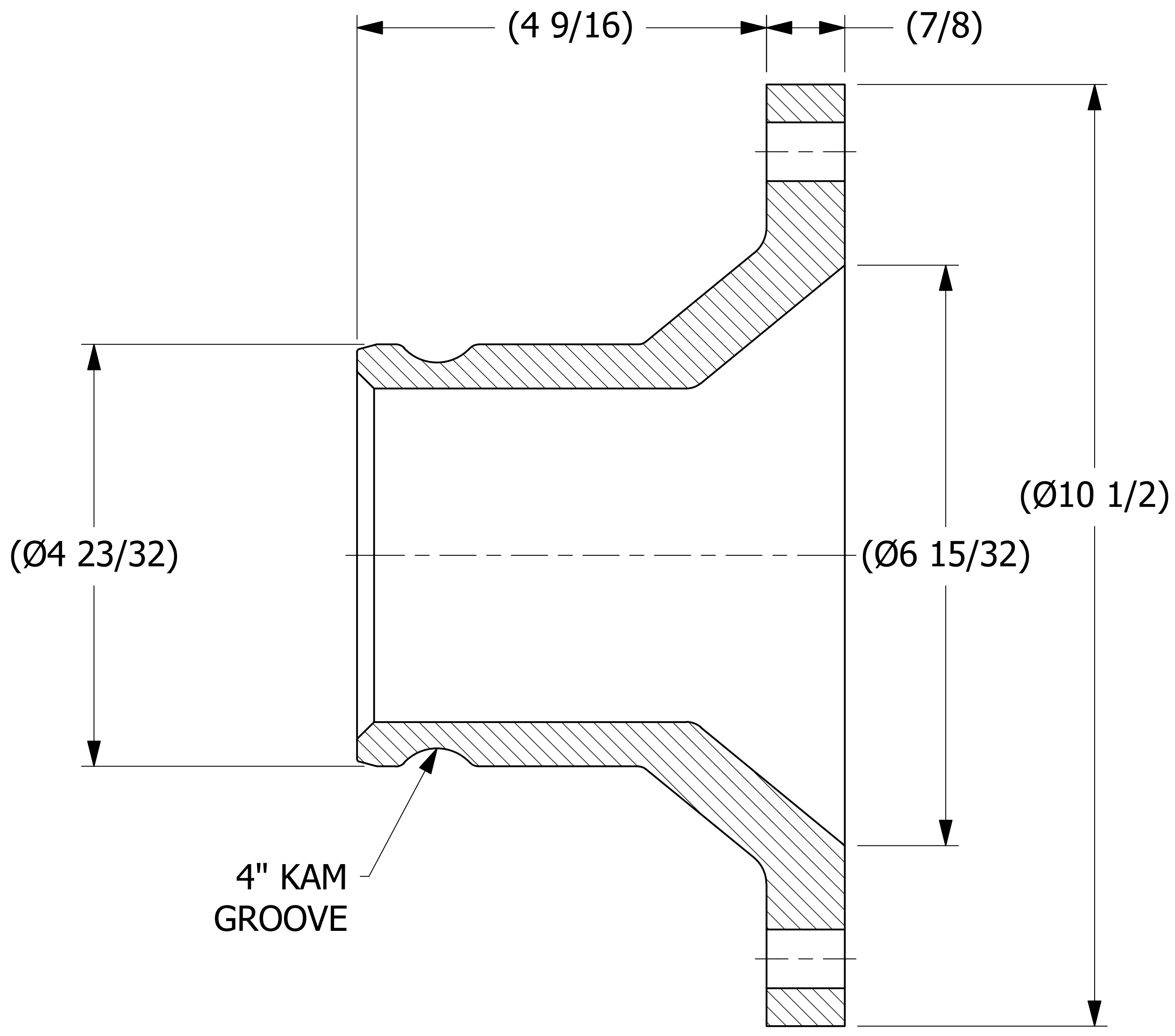
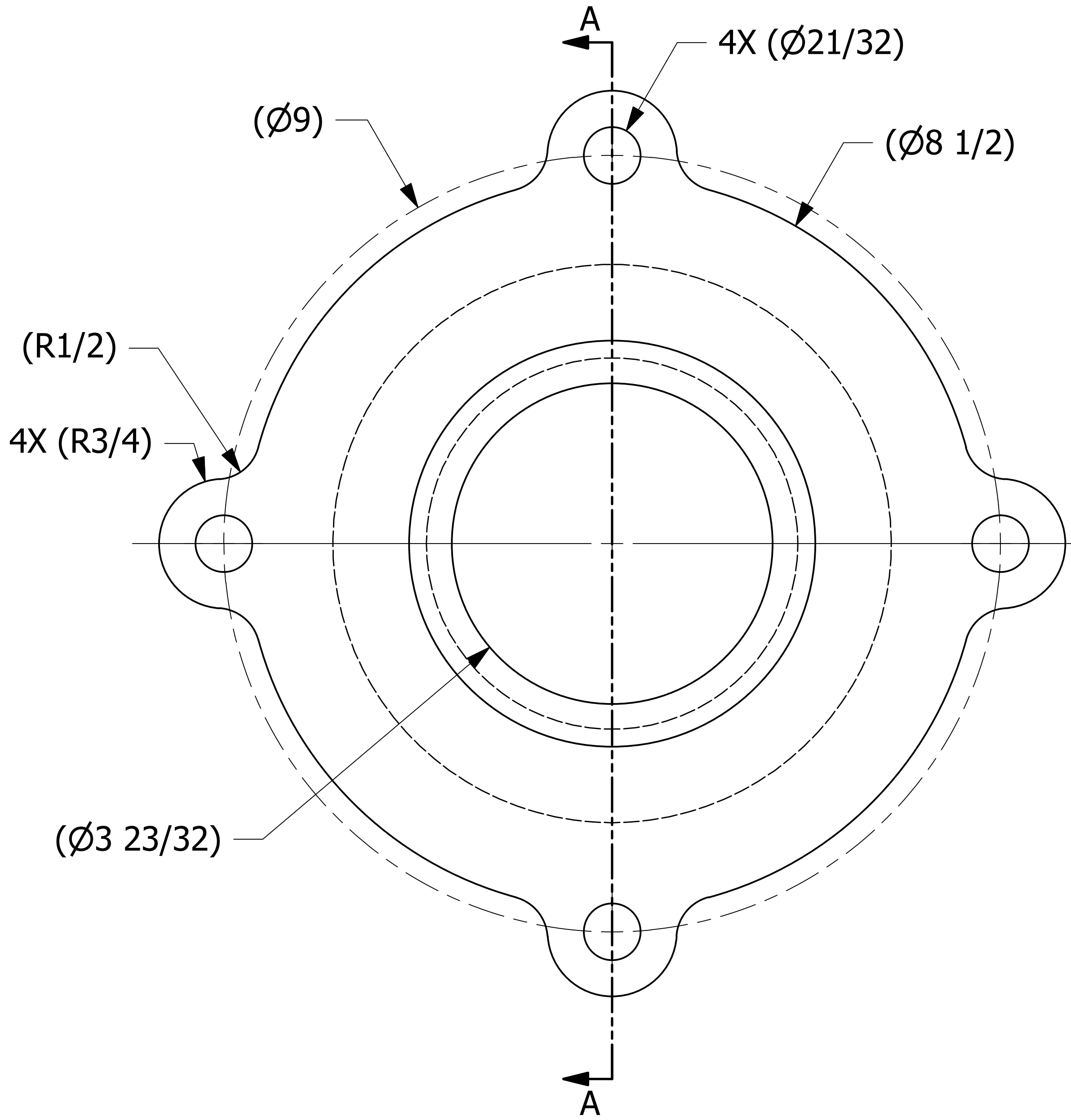

SECTION A-A

UNLESS OTHERWISE SPECIFIED
DIMENSIONAL TOLERANCES
FRACTIONAL: $\pm 1/16$
X.XX: $\pm .03$
X.XXX: $\pm .015$
ANGULAR: $\pm 1^\circ$
DEBURR ALL SHARP EDGES.
ALL MACHINED SURFACES TO
HAVE A 125 RMS FINISH
UNLESS NOTED OTHERWISE.
THIRD ANGLE PROJECTION

DRAWN BY: BRW
CHECKED BY:
PROTOTYPE DATE: 1/29/1996
APPROVED FOR PRODUCTION BY: BRW
PRODUCTION DATE: 1/29/1996
SIZE: D
DRAWING #: 7876

G	BP	1/6/23	202301061639	BP
REV	BY	DATE	REF #	PUB
SALCO PRODUCTS, INC.				
PART NAME: QUICK DISCONNECT ADAPTER 4" FLANGED				
MATERIAL: ASTM A743 GR. CF-8M 316 SS				
PROJECT #:			SHEET #: 1 OF 2	SCALE: 1:1
PART #: K4SWF				

